



# EST122

## Electric Stacker 1.2T

- Strong chassis
- Rigid mast
- Easy operation
- Efficient hydraulic system

**EP EQUIPMENT CO.,LTD**  
[www.ep-ep.com](http://www.ep-ep.com)



## FEATURES

### Strong chassis

The side impact beam, plates, and boxes make the chassis stronger and can greatly reduce stress and deformation caused by heavy load.

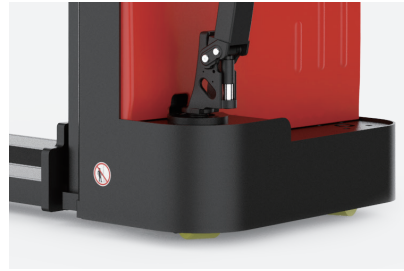

### Rigid mast

The rigidity of the mast is greatly improved by its beam structure to provide smooth lifting and stacking for daily operation.

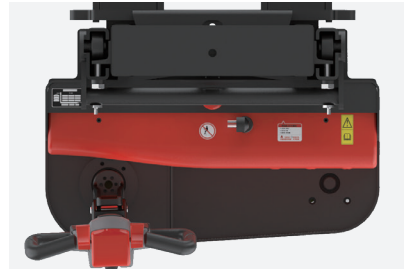

### Easy operation

The extra-long and offset tiller with the crawl speed button provides EST122 a better visibility and nimble maneuverability when operating in tight space.

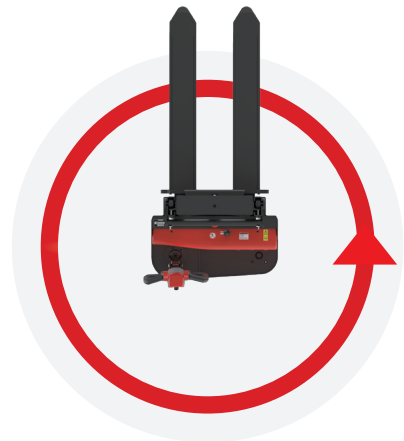

### Efficient hydraulic system

High quality hydraulic pump ensures very little noise, maximum efficiency, durability and shortens lifting time.

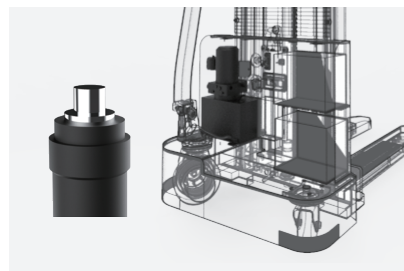

# Electric Stacker 1.2T

## EST122

Distinguishing mark				
1.1	Manufacturer			EP
1.2	Model designation			EST122
1.3	Drive unit			electrics
1.4	Operator type			pedestrian
1.5	rated capacity	Q	kg	1200
1.6	Load center distance	c	mm	600
1.8	Load distance, centre of drive axle to fork	x	mm	808
1.9	Wheelbase	y	mm	1209
Weight				
2.1	Service weight (include battery)		kg	550
2.2	Axle loading, laden driving side/loading side		kg	912/1138
2.3	Axle loading, unladen driving side/loading side		kg	449/101
Types,Chassis				
3.1	Tyre type Driving wheels/Loading wheels			PU/PU
3.2	Tyre size, driving wheels (diameter×width)		mm	Ø210×70
3.3	Tyre size, loading wheels (diameter×width)		mm	Ø74×88
3.4	Tyre size, caster wheels (diameter×width)		mm	Ø130×55
3.5	Wheels, number driving, caster/loading (x=drive wheels)		mm	1x +1/4
3.6	Track width, front,driving side	b10	mm	616
3.7	Track width,rear,loading side	b11	mm	433
Dimensions				
4.1	Tilt of mast/fork carriage forward/backward	α/ β	mm	
4.2	Height, mast lowered	h1	mm	2080
4.3	Free lift	h2	mm	0
4.4	Lift height	h3	mm	2920
4.5	Height, mast extended	h4	mm	3545
4.6	Initial lift	h5	mm	
4.9	Height drawbar in driving position min./max.	h14	mm	750/ 1340
4.10	Height of wheel arms	h8	mm	
4.15	Lowered height	h13	mm	90
4.19	Overall length	l1	mm	1700
4.20	Length to face of forks	l2	mm	526
4.21	Overall width	b1	mm	800
4.22	Fork dimensions	s/ e/ l	mm	60/ 190/ 1150
4.24	Fork carriage width	b3	mm	795
4.25	Distance between fork-arms	b5	mm	570/685
4.26	Distance between wheel arms	b4	mm	
4.31	Ground clearance, laden, below mast	m1	mm	
4.32	Ground clearance, center of wheelbase	m2	mm	37
4.34.1	Aisle width for pallets 1000 × 1200 crossways	Ast	mm	2233
4.34.2	Aisle width for pallets 800 × 1200 lengthways	Ast	mm	2148
4.35	Turning radius	Wa	mm	1392
Performance data				
5.1	Travel speed, laden/ unladen		km/h	3.7/4.0
5.2	Lifting speed, laden/ unladen		m/ s	0.08/0.135
5.3	Lowering speed, laden/ unladen		m/ s	0.105/0.097
5.8	Max. gradeability, laden/unladen		%	3/10
5.10	Service brake type			Electromagnetic
Electric-engine				
6.1	Drive motor rating S2 60 min		kW	0.75
6.2	Lift motor rating at S3 15%		kW	2.2
6.3	The maximum allowed size battery		mm	260x165x170
6.4	Battery voltage/nominal capacity		V/ Ah	2x12/80
6.5	Battery weight		kg	2x19.6
Addition data				
8.1	Type of drive unit			DC

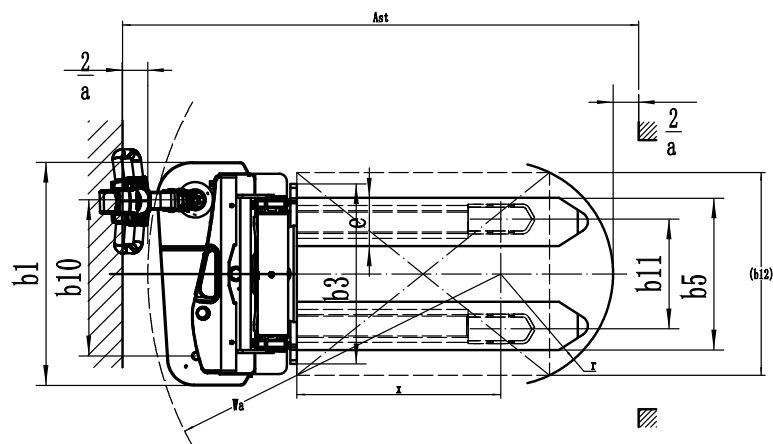
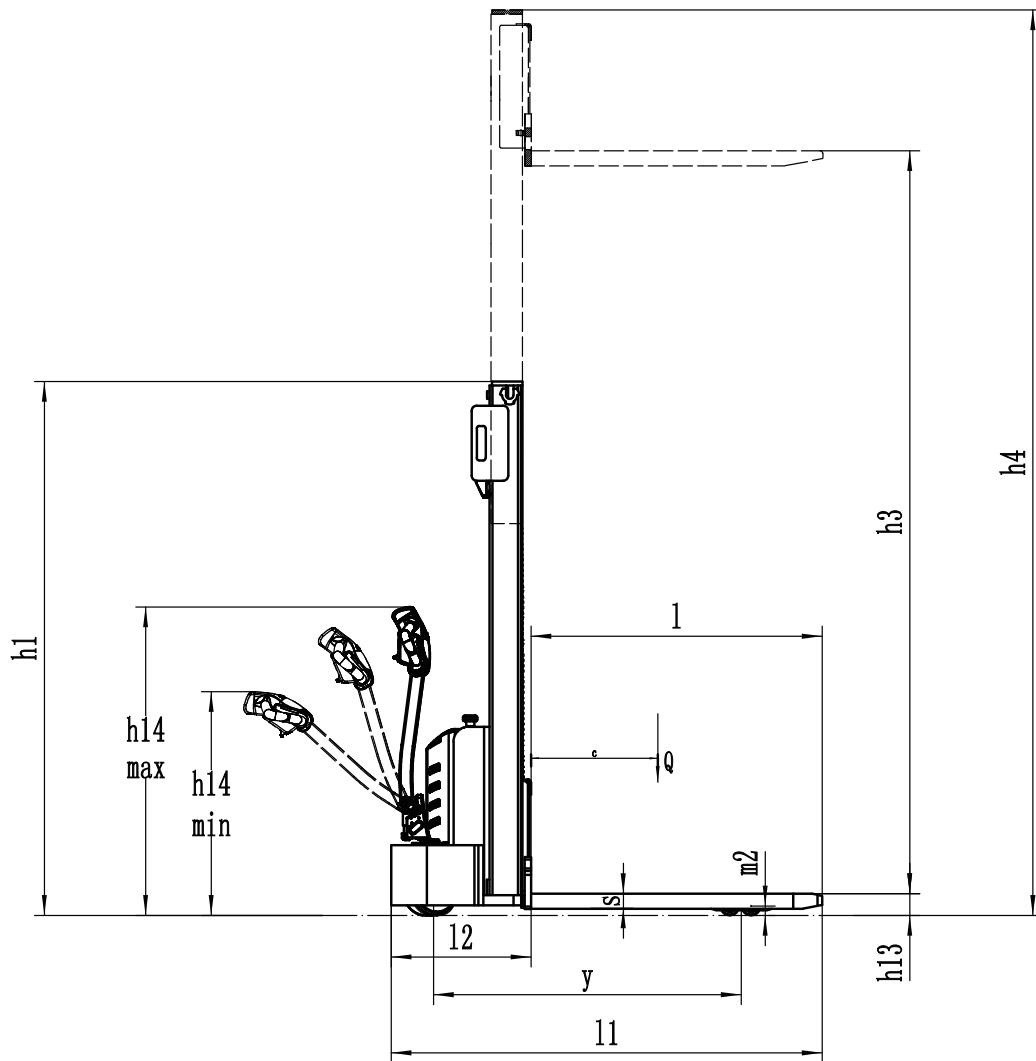

## Mast Option:

mast types	Lift	$h_3+h_{13}$	Lowered mast height	$h_1$	Free lift	$h_2$	Extended mast height	$h_4$
Duplex ZT		2516	1856		—		3071	
		2716	1956		—		3271	
		3016	2106		—		3571	
		3316	2256		—		3871	