



JX2-4

Order-picking Truck 1.0t

Meet exactly the same operators' preference as high lifting order picker
Medium level order picker for various applications

EP EQUIPMENT CO.,LTD
www.ep-ep.com



Order-picking Truck 1.0t

JX2-4

Distinguishing mark					
1.1	Manufacturer			EP	EP
1.2	Model designation			JX2-4(3200)	JX2-4(3600)
1.3	Drive unit			Electric	Electric
1.4	Operator type			standing	standing
1.5	rated capacity	Q	kg	1000	1000
1.6	Load center distance	c	mm	600	600
1.8	Load distance, centre of drive axle to fork	x	mm	115	115
1.9	Wheelbase	y	mm	1365	1365
Weight					
2.1	Service weight (include battery)		kg	1900	1965
2.2	Axle loading, laden driving side/loading side		kg	730/2170	760/2205
2.3	Axle loading, unladen driving side/loading side		kg	1170/730	1200/765
Types,Chassis					
3.1	Tyre type, Driving wheels/Loading wheels			PU/Rubber	PU/Rubber
3.2	Tyre size, driving wheels (Diameter×Width)		mm	Φ260×105	Φ260×105
3.3	Tyre size, loading wheels (Diameter×Width)		mm	Φ165×120	Φ165×120
3.5	Wheels, number driving, caster/loading (x=drive wheels)		mm	1x,2/2	1x,2/2
3.6	Track width, front,driving side	b10	mm	570	570
3.7	Track width,rear,loading side	b11	mm	770	770
Dimensions					
4.2	Height, mast lowered	h1	mm	2170	2360
4.4	Lift height)	h3	mm	3137	3597
4.5	Height, mast extended)	h4	mm	5410	5975
4.7	Height of overhead guard (cabin)	h6	mm	2270	2270
4.8	Seat height/standing height)	h7	mm	220	220
4.14	Stand height, elevated	h12	mm	3360	3815
4.15	Lowered height	h13	mm	63	63
4.19	Overall length	l1	mm	2750	2750
4.20	Length to face of forks	l2	mm	1680	1680
4.21	Overall width	b1/ b2	mm	860	860
4.22	Fork dimensions	s/ e/ l	mm	40/100/1070	40/100/1070
4.25	Outside width of the forks	b5	mm	540	540
4.26	Fork lift height	h3+h13	mm	3200	3600
4.27	width of pallet clamp	N	mm	25-150	25-150
4.32	Ground clearance, center of wheelbase	m2	mm	50	50
4.34.1	Aisle width for pallets 1000 × 1200 crossways	Ast	mm	3100	3100
4.34.2	Aisle width for pallets 800 × 1200 lengthways	Ast	mm	3150	3150
4.35	Turning radius	Wa	mm	1600	1600
Performance data					
5.1	Travel speed, laden/unladen (h12: 0-610)		km/ h	8	8
	Travel speed, laden/unladen (h12: 610-1940)		km/ h	3.7	3.7
	Travel speed, laden/unladen (h12: 1940-2600)		km/ h	2.1	2.1
	Travel speed, laden/unladen (h12: 2600-MAX)		km/ h	0.8	0.8
5.1.1	Travel speed, laden/unladen backwards (h12: 0-610)		km/ h	8	8
	Travel speed, laden/unladen backwards (h12: 610-1940)		km/ h	3.7	3.7
	Travel speed, laden/unladen backwards (h12: 1940-2600)		km/ h	2.1	2.1
	Travel speed, laden/unladen backwards (h12: 2600-MAX)		km/ h	0.8	0.8
5.2	Lifting speed, laden/ unladen		m/ s	0.13/0.16	0.13/0.16
5.3	Lowering speed, laden/ unladen)		m/ s	0.16/0.18	0.16/0.18
5.80	Max. gradeability, laden/unladen		%	/	/
5.10	Service brake type			Electromagnetic	Electromagnetic
Electric-engine					
6.1	Drive motor rating S2 60 min		kW	4	4
6.2	Lift motor rating at S3 15%		kW	3	3
6.3	The maximum allowed size battery		mm	740*275*630	740*275*630
6.4	Battery voltage/nominal capacity K5		V/ Ah	24/360	24/360
6.5	Battery weight		kg	330	330
Addition data					
8.1	Type of drive unit			AC	AC
10.5	Steering type			Electric	Electric
10.7	Sound pressure level at the driver's ear		dB (A)	70	70

1.The parameters in the table are of the standard model. For more information please contact us.
2.The parameters are subject to change without notice.

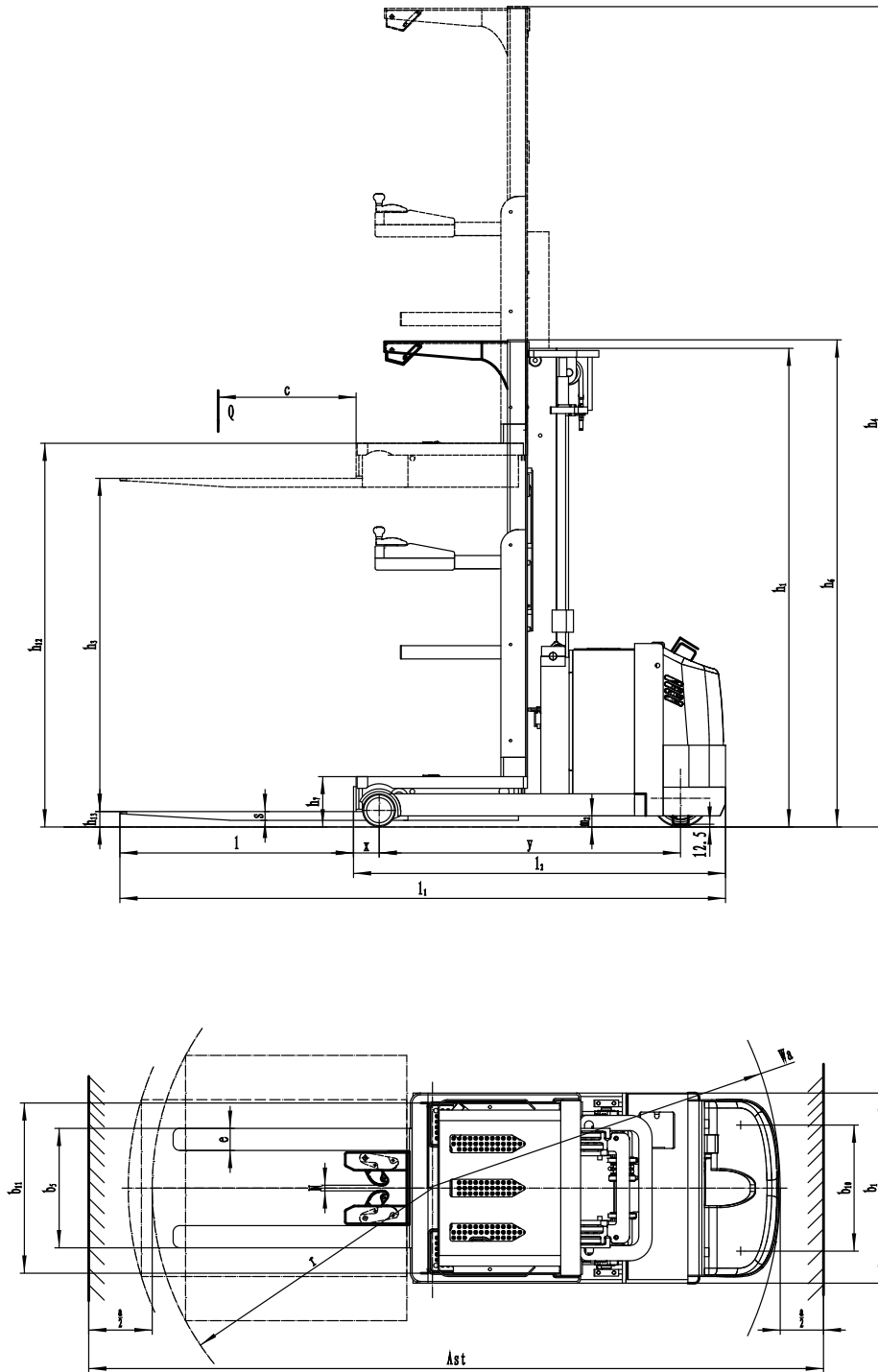

$$Ast = Wa + r + a$$

$$a = 200$$