



ES 10-10ES/ES12-12ES

Electric Stacker 1.0/1.2t

- Electric Stacker With Smallest Working Space Needed
- Innovative Design of Low Energy Consumption and High Reliability
- Long & Aside Tiller Design Makes Operations Safe and Convenient

LHON
TECHNOLOGY

EP EQUIPMENT CO.,LTD
www.ep-ep.com



FEATURE

Performance

- Robust Structure;
- Highly specialized drive and hydraulic system ensure excellent driving performance and high reliability.
- Low-noise and durable hydraulic unit, high quality cylinder as well as hose ensure high reliability of hydraulic system.
- AMP connector and durable electric wires greatly reduce malfunctions of components.



Safety

- Safety hydraulic design prevents mast from falling down abruptly when oil pipes cut off.
- Belly button prevents truck from hitting operator.
- By simply pressing emergency disconnect, power supply will be immediately interrupted.
- Multi lifting limited switch ensures travel safety.
- Truck automatically switches to low speed mode, when lifting height is higher than setting height.
- Anti-rolling back braking device ensures trucks don't roll back on ramps.

Operation

- Ergonomic tiller head for effortless and comfortable operations.
- Tiller with long arm for smooth steering.
- Compact chassis design offers smallest turning radius needed.
- Side operating ensures excellent visibility.
- On-board Charger.

Maintenance

- 24V/80Ah Li-ion battery.
- Battery display indicator with hour meter, reminds operator of charging on time (optional).
- Easy Maintenance — detachable rear panel.
- Self-Diagnostics signal on the digital display allows easy trouble-shooting.
- Easy Access of Hand Set.
- Low-voltage Cut-off Protection.

Electric Stacker 1.0/1.2t

ES10-10ES/ES12-12ES

Distinguishing mark					
1.1	Manufacturer			EP	EP
1.2	Model designation			ES10-10ES	ES12-12ES
1.3	Drive unit			Electrics	electrics
1.4	Operator type			pedestrian	pedestrian
1.5	rated capacity	Q	kg	1000	1200
1.6	Load center distance	c	mm	600	600
1.8	Load distance, centre of drive axle to fork	x	mm	795	795
1.9	Wheelbase	y	mm	1240	1240
Weight					
2.1	Service weight (include battery)		kg	535	624
2.2	Axle loading, laden driving side/loading side		kg	660/875	826/798
2.3	Axle loading, unladen driving side/loading side		kg	415/120	536/125
Types, Chassis					
3.1	Tyre type Driving wheels/Loading wheels			PU/PU	PU/PU
3.2	Tyre size, driving wheels (diameter×width)		mm	Ø210×70	Ø210×70
3.3	Tyre size, loading wheels (diameter×width)		mm	Ø80×60	Ø80×60
3.4	Tyre size, caster wheels (diameter×width)		mm	Ø130×55	Ø130×55
3.5	Wheels, number driving, caster/loading (x=drive wheels)		mm	1x +1/4	1x +1/4
3.6	Track width, front, driving side	b ₁₀	mm	533	533
3.7	Track width, rear, loading side	b ₁₁	mm	400	400
Dimensions					
4.1	Tilt of mast/fork carriage forward/backward	α/ β	°		
4.2	Height, mast lowered	h ₁	mm	2026	2056
4.3	Free lift	h ₂	mm		
4.4	Lift height	h ₃	mm	2927	2930
4.5	Height, mast extended	h ₄	mm	3487	3487
4.6	Initial lift	h ₅	mm		
4.9	Height drawbar in driving position min./max.	h ₁₄	mm	860/ 1200	860/ 1200
4.10	Height of wheel arms	h ₈	mm		
4.15	Lowered height	h ₁₃	mm	88	88
4.19	Overall length	l ₁	mm	1740	1740
4.20	Length to face of forks	l ₂	mm	590	590
4.21	Overall width	b ₁ / b ₂	mm	800	800
4.22	Fork dimensions	s/ e/ l	mm	55/160/1150	60/ 170/ 1150
4.24	Fork carriage width	b ₃	mm	600	680
4.25	Outside width of the forks	b ₅	mm	560	570
4.26	Distance between wheel arms	b ₄	mm		
4.31	Ground clearance, laden, below mast	m ₁	mm		
4.32	Ground clearance, center of wheelbase	m ₂	mm	30	30
4.34.1	Aisle width for pallets 1000 × 1200 crossways	Ast	mm	2225	2225
4.34.2	Aisle width for pallets 800 × 1200 lengthways	Ast	mm	2150	2150
4.35	Turning radius	Wa	mm	1408	1408
Performance data					
5.1	Travel speed, laden/ unladen		km/ h	4/4.5	4/4.5
5.2	Lifting speed, laden/ unladen		m/ s	0.12/0.22	0.12/0.22
5.3	Lowering speed, laden/ unladen		m/ s	0.22/0.11	0.22/0.11
5.8	Max. gradeability, laden/unladen		%	3/10	43900
5.10	Service brake type			Electromagnetic	Electromagnetic
Electric-engine					
6.1	Drive motor rating S2 60 min		kW	0.65	0.65
6.2	Lift motor rating at S3 15%		kW	2.2	2.2
6.3	The maximum allowed size battery		mm	300x190x365	300x190x365
6.4	Battery voltage/nominal capacity K20		V/ Ah	24/80	24/80
6.5	Battery weight		kg	23	23
Addition data					
8.1	Type of drive unit			DC	DC
10.5	Steering type			Mechanical	Mechanical
10.7	Sound pressure level at the driver's ear		dB(A)	74	74

If there are improvements of technical parameters or configurations, no further notice will be given.
The diagram shown may contain non-standard configurations.

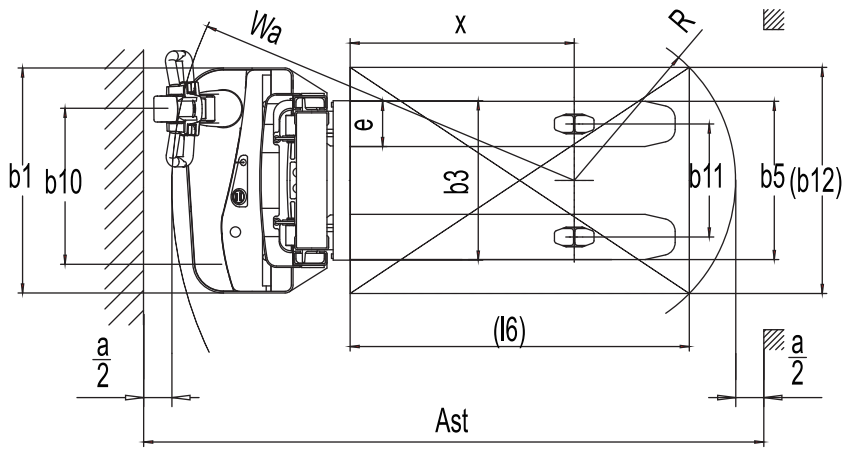
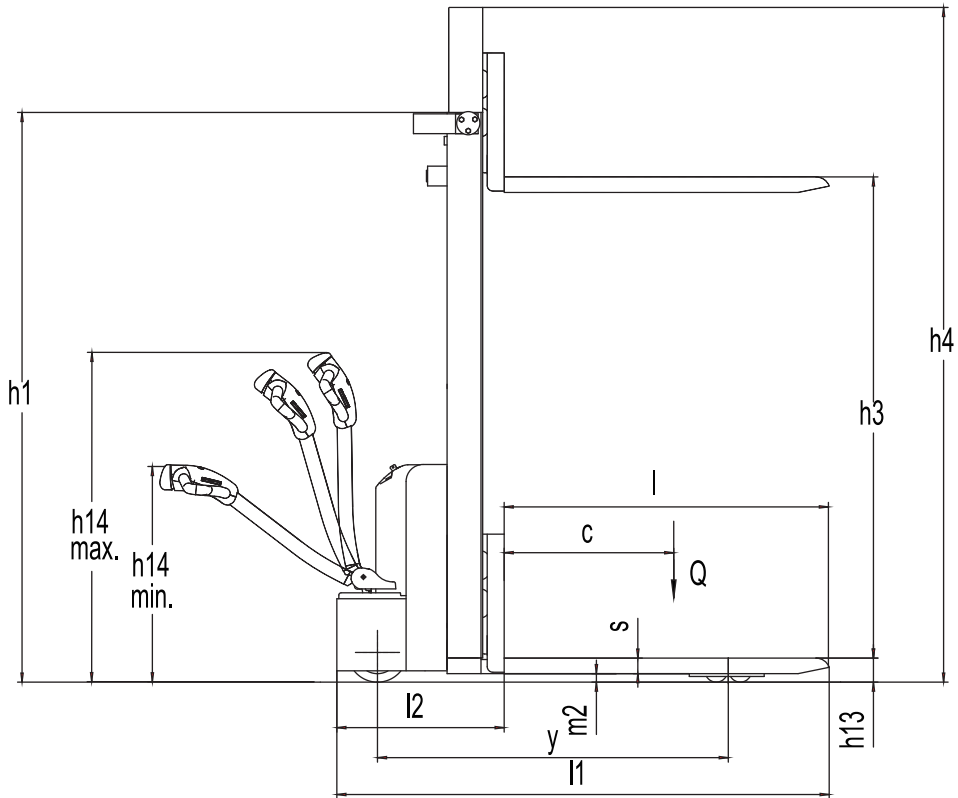

RATED CAPACITIES GRAPH

ES10-10ES

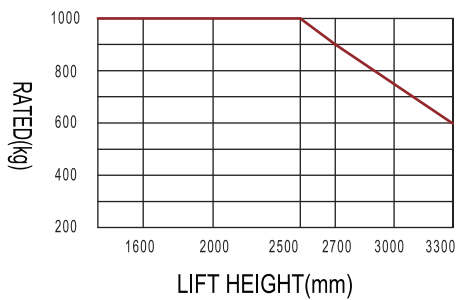

RATED CAPACITIES GRAPH

ES12-12ES

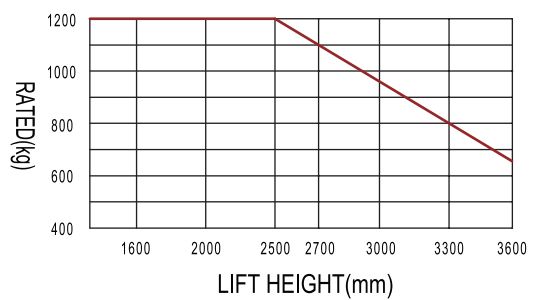

Mast Option

ES10-10ES

mast types	Lift h3+h13 (mm)	Lowered mast height h1 (mm)	Free lift h2 (mm)	Extended mast height h4 (mm)
Duplex ZT	2515	1772	—	2987
	2715	1872	—	3187
	3015	2022	—	3487
	3315	2172	—	3787

ES12-12ES

mast types	Lift h3+h13 (mm)	Lowered mast height h1 (mm)	Free lift h2 (mm)	Extended mast height h4 (mm)
Duplex ZT	1205	1575	1120	1575
	1405	1775	1320	1775
	1605	1975	1520	1975
	1705	2075	1705	2075
	2515	1802	—	3021
	2715	1902	—	3221
	3015	2052	—	3521
	3315	2202	—	3821
	3615	2352	—	4121

Option

Options	ES10-10ES	ES12-12ES
Fork width	○685mm/600mm	○685mm/600mm
Special backrest	—	—
Battery indicator with hour meter	○	○
Driving wheel	○PU wheel with Pattern	○PU wheel with Pattern
half speed function in turning	—	—
Mast screen	●organic glass	●organic glass
Height limitation	○	○
Note: ● standard ○ option — NA		