



# EPT16-ET/ EPT20-ET

Electric pallet truck 1.6/2.0t

- 48V super power, Ideal out-door solution, Longer run time

## Mastering urban logistics

Designed to cope with complex environment



High Obstacle   Road Bumps   Narrow Space

EP EQUIPMENT CO.,LTD  
[www.ep-ep.com](http://www.ep-ep.com)



## FEATURE

- **Light service weight, high rated capacity, not limited by floor type:**

Minimum size vs 2.0ton capacity, with 1465mm turning radius.

- **High passability design:**

EPT16-ET can easily drive through 100mm height barrier with patent roll-over load wheel and large drive wheel.

80mm lowered height and 140mm lifting height giving flexibility for pallet and application.

- **Easy disassembly handle design:**

Pin through tiller style reduces shipping cost and installation time greatly.

- **DC brushless permanent magnet motor:**

Life time maintenance free brushless permanent magnet motor.

- **Innovative frame design:**

Distribute majority weight to bottom chassis by patent designed cylinder structure.

- **Shock absorb chassis design:**

Special linkage design, minimize the driving difference between smooth ground and rough ground.

- **48V electronic system:**

48V electronic system increases efficiency and reliability.

- **Easy maintenance:**

Electronic system and batteries can be completely exposed by pressing one-touch locker.

Drive wheel can be replaced by loosening one nut.

Retractable charging cord.

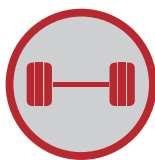

Rated Capacity up to

**2000kg**

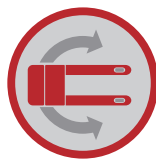

Turning Radius

**1465mm**



Driving Wheels diameter x width

**250x74mm**



Lowered Height **80mm** | Max Lifting Height **220mm**



Optional Turnable load wheel to overcome obstacle **100mm**  
(Note: Only available for EPT16-ET)



Max. gradeability laden/unladen **8% | 16%**

# Electric Pallet Truck 1.6/2.0t

## EPT16-ET/EPT20-ET

Distinguishing mark					
1.1	Manufacturer			EP	EP
1.2	Model designation			EPT16-ET (With roll-over load wheel)	EPT20-ET
1.3	Drive unit			Battery	Battery
1.4	Operator type			pedestrian	pedestrian
1.5	rated capacity	Q	kg	1600	2000
1.6	Load center distance	c	mm	600	600
1.8	Load distance	x	mm	875/976	874/962
1.9	Wheelbase	y	mm	1249/1350	1248/1336
Weight					
2.1	Service weight (include battery)		kg	215	220
2.2	Axle loading, laden driving side/loading side		kg	629/1189	722/1498
2.3	Axle loading, unladen driving side/loading side		kg	180/35	180/40
Types, Chassis					
3.1	Tyre type driving wheels/loading wheels			Rubber/PU	PU/PU
3.2	Tyre size, driving wheels (diameter×width)		mm	Φ250×74	Φ250×74
3.3	Tyre size, loading wheels (diameter×width)		mm	4xΦ80×40	4x Φ78×60
3.4	Tyre size, caster wheels (diameter×width)		mm	Φ74×48	Φ74×48
3.5	Wheels, number driving, caster/loading (x=drive wheels)		mm	1x 2/4	1x 2/4
3.6	Track width, front, driving side	b <sub>10</sub>	mm	435	435
3.7	Track width, rear, loading side	b <sub>11</sub>	mm	410 (535)	410 (535)
Dimensions					
4.4	Lift height	h <sub>3</sub>	mm	140	140
4.9	Height drawbar in driving position min./max.	h <sub>14</sub>	mm	750/1170	750/1170
4.15	Lowered height	h <sub>13</sub>	mm	80	80
4.19	Overall length	l <sub>1</sub>	mm	1685	1685
4.20	Length to face of forks	l <sub>2</sub>	mm	535	535
4.21	Overall width	b <sub>1</sub> / b <sub>2</sub>	mm	560 (685)	560 (685)
4.22	Fork dimensions	s/ e/ l	mm	50/150/1150	50/150/1150
4.25	Outside width of the forks	b <sub>5</sub>	mm	560 (685)	560 (685)
4.32	Ground clearance, center of wheelbase	m <sub>2</sub>	mm	30	30
4.34.1	Aisle width for pallets 1000 × 1200 crossways	Ast	mm	1734	1734
4.34.2	Aisle width for pallets 800 × 1200 lengthways	Ast	mm	1934	1934
4.35	Turning radius	Wa	mm	1510	1496
Performance data					
5.1	Travel speed, laden/ unladen	km/ h	km/h	4/5.5	4/5.5
5.2	Lifting speed, laden/ unladen		m/ s	0.018/0.037	0.018/0.037
5.3	Lowering speed, laden/ unladen		m/ s	0.032/0.038	0.032/0.038
5.8	Max. gradeability, laden/unladen		%	10/20	8/16
5.10	Service brake type			Electromagnetic	Electromagnetic
Electric engine					
6.1	Drive motor rating S2 60 min		kW	0.75	0.75
6.2	Lift motor rating at S3 15%		kW	0.84	0.84
6.3	The maximum allowed size battery		mm	255*170*200	255*170*200
6.4	Battery voltage/nominal capacity K20		V/ Ah	12*4/30	12*4/30
6.5	Battery weight		kg	9.5*4	9.5*4
Addition data					
8.1	Type of drive control			DC	DC
10.5	Steering type			Mechanical	Mechanical
10.7	Sound pressure level at the driver's ear		dB (A)	74	74

1. The parameters in the table are of the standard model. For more information please contact us.

2. The parameters are subject to change without notice.

## Option

Options	type	EPT20-ET
Fork length		○800/915/1000/1070/1150/1220/1300
Climbing wheel load 1.6 T		○
Driving wheel		○Rubber wheel
Special backrest		○1220mm (48in) /1520mm (60in)
Note: Fork length < 1400, capacity 2.0T; Fork length ≥ 1400, capacity 1.6T		
Note: ● standard ○ option — NA		

# EPT16-ET:

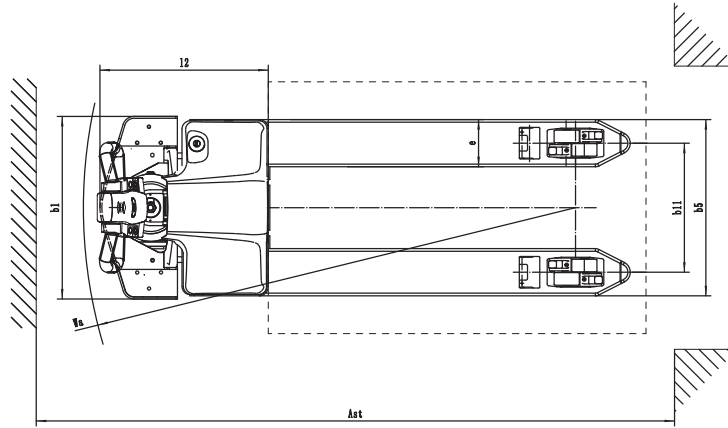
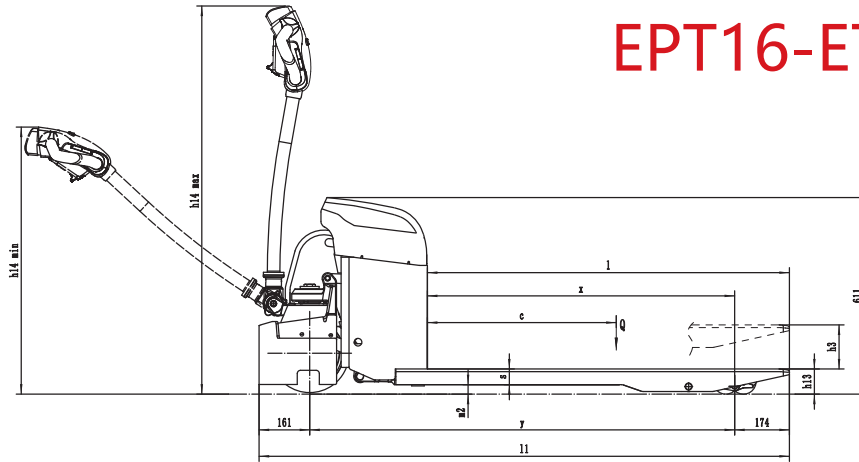

# EPT20-ET:

