

**MAX-8**



Let's grow together 

# MAX-8

Excellent Performances & Reliability

## CPD30/35FT8(-H)

Four-wheel Electric Forklift 3.0/3.5t

EP EQUIPMENT CO.,LTD  
[www.ep-ep.com](http://www.ep-ep.com)

## Four-wheel Electric Forklift 3.0/3.5t CPD30/35FT8(-H)

Distinguishing mark						
1.1	Manufacturer		EP	EP	EP	EP
1.2	Model designation		CPD30FT8	CPD30FT8-H	CPD35FT8	CPD35FT8-H
1.3	Drive unit		Electrics	Electrics	Electrics	Electrics
1.4	Operator type		seated	seated	seated	seated
1.5	rated capacity	Q t	3	3	3.5	3.5
1.6	Load center distance	c mm	500	500	500	500
1.8	Load distance, centre of drive axle to fork	x mm	500	500	500	500
1.9	Wheelbase	y mm	1622	1622	1622	1622
Weight						
2.1	Service weight (include battery)	kg	4980	4980	5100	5100
2.2	Axle loading, laden driving wheels /steering wheels	kg	7230/750	7230/750	7800/800	7800/800
2.3	Axle loading, unladen driving wheels /steering wheels	kg	2140/2840	2140/2840	2200/2900	2200/2900
Types,Chassis						
3.1	Tyre type,driving wheels /steering wheels		pneumatic	pneumatic	pneumatic	pneumatic
3.2	Tyre size, driving wheels		28X9-15	28X9-15	28X9-15	28X9-15
3.3	Tyre size, steering wheels		18X7-8	18X7-8	18X7-8	18X7-8
3.5	Wheels, number driving/steering (x=drive wheels)	mm	2x/ 2	2x/ 2	2x/ 2	2x/ 2
3.6	Tread, Driving wheels	b <sub>10</sub> mm	1000	1000	1000	1000
3.7	Tread, Steering wheels	b <sub>11</sub> mm	980	980	980	980
Dimensions						
4.1	Tilt of mast/fork carriage forward/backward	$\alpha/\beta$ (°)	6/ 12	6/ 12	6/ 12	6/ 12
4.2	Height, mast lowered	h <sub>1</sub> mm	2220	2220	2220	2220
4.3	Free lift (load backrest)	h <sub>2</sub> mm	120	120	120	120
4.4	Lift height	h <sub>3</sub> mm	3000	3000	3000	3000
4.5	Height, mast extended	h <sub>4</sub> mm	4105	4105	4105	4105
4.7	Height of overhead guard (cabin)	h <sub>6</sub> mm	2220	2220	2220	2220
4.8	Seat height	h <sub>7</sub> mm	1110	1110	1110	1110
4.12	Tow center of pin height	h <sub>10</sub> mm	310	310	310	310
4.19	Overall length	l <sub>1</sub> mm	3620	3620	3620	3620
4.20	Length to face of forks	l <sub>2</sub> mm	2550	2550	2550	2550
4.21	Overall width	b <sub>1</sub> / b <sub>2</sub> mm	1220	1220	1220	1220
4.22	Fork dimensions	s/ e/ l mm	45×125×1070	45×125×1070	45×125×1070	45×125×1070
4.23	Fork carriage class/type A, B		3A	3A	3A	3A
4.24	Fork carriage width	b <sub>3</sub> mm	1180	1180	1180	1180
4.31	Ground clearance, laden, below mast	m <sub>1</sub> mm	130	130	130	130
4.32	The minimum ground clearance of frame	m <sub>2</sub> mm	120	120	120	120
4.34.1	Aisle width for pallets 1000 × 1200 crossways	Ast mm	4520	4520	4520	4520
4.34.2	Aisle width for pallets 800 × 1200 lengthways	Ast mm	4560	4560	4560	4560
4.35	Turning radius	Wa mm	2300	2300	2300	2300
Performance data						
5.1	Travel speed, laden/ unladen	km/ h	11/ 12	11/ 12	11/ 12	11/ 12
5.2	Lifting speed, laden/ unladen	m/ s	0.23/ 0.37	0.22/ 0.37	0.23/ 0.37	0.22/ 0.37
5.3	Lowering speed, laden/ unladen	m/ s	0.50/ 0.48	0.50/ 0.48	0.50/ 0.48	0.50/ 0.48
5.5	Drawbar pull, laden/unladen	N	—	—	—	—
5.6	Max. drawbar pull, laden/unladen (time)	N	18000	18000	18000	18000
5.7	Gradeability, laden/unladen	%	—	—	—	—
5.8	Max. gradeability, laden/unladen	%	10.5/12	10.5/12	10.5/12	10.5/12
5.10	Service brake type		Hydraulic / Mechanical	Hydraulic / Mechanical	Hydraulic / Mechanical	Hydraulic / Mechanical
	park brake type		Mechanical	Mechanical	Mechanical	Mechanical
Electric-engine						
6.1	Drive motor rating S2 60 min	kW	16.6	16.6	16.6	16.6
6.2	Lift motor rating at S3 15%	kW	10	13	10	13
6.3	The maximum allowed size battery	mm	—	—	—	—
6.4	Battery voltage/nominal capacity K5		80/500(Max550)	80/500(Max550)	80/500(Max550)	80/500(Max550)
6.5	Battery weight	kg	1350	1350	1350	1350
Addition data						
8.1	Type of drive unit		AC	AC	AC	AC
10.5	Steering type		—	—	—	—
10.7	Sound pressure level at the driver's ear	dB (A)	75	76	75	76

- 1.The parameters in the table are of the standard model. For more information, please contact us.
- 2.The parameters are subject to change without notice.

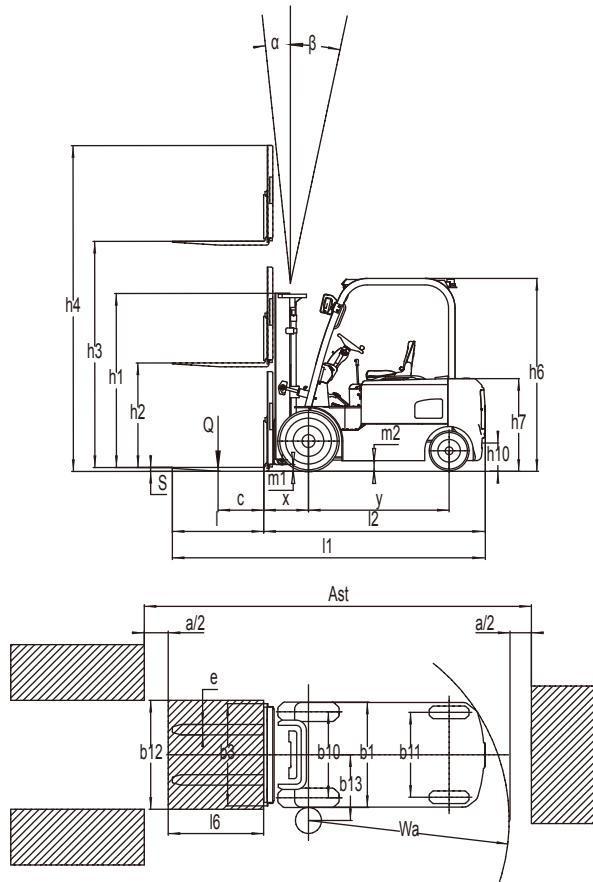

## Option

options	CPD30/35FT8(-H)
Fork length	•
high capacity battery	•
Import battery	•
Rubber solid tyre	•
Green solid tire	•
Cold storage (Apply to -20 C )	•
Lateral battery change	•
Fork weighing system	•
Customized Overhead height	•
Mast lifting height	•
Attachment	•
Integrated side shift	•
LED Front working light	•
Rear working light	•
Warning light	•
fire extinguisher	•
Auto-filling water system	•
Susepnsion seat	•
Hearer	•
Front window with wiper	•
Rear window with wiper	•
Full cabin	•
OPS	•
Speical backrest	•
battery trolley for lateral battery extraction	•
FAN	•
Charger (220/380V )	•
Dual Mirrors	•
dual front wheel	•
Special modification for Drive-in Racking	•



# Mast Option

## CPD30-35FT8 mast types

Type	Model	Max.fork height h3 mm	Overall height			Free lift		Front Overhang X		Tilt range		Capacity			
			Lowered h1 mm	Extended		Without backrest mm	With backrest h2 mm	3t mm	3.5t mm	FWD α Deg	BWD β Deg	Load capacity at 500 mm		Double tyre	
				Without backrest mm	With backrest mm							3t kg	3.5t kg	3t kg	3.5t kg
Duplex ZT	2W200	2000	1500	2705	3105	120	120	500	500	6	12	3000	3500	3000	3500
	2W250	2500	1750	3205	3605	120	120	500	500	6	12	3000	3500	3000	3500
	2W270	2700	1850	3405	3805	120	120	500	500	6	12	3000	3500	3000	3500
	2W300	3000	2000	3705	4105	120	120	500	500	6	12	3000	3500	3000	3500
	2W330	3300	2150	4005	4405	120	120	500	500	6	12	3000	3500	3000	3500
	2W350	3500	2250	4205	4605	120	120	500	500	6	12	3000	3500	3000	3500
	2W360	3600	2300	4305	4705	120	120	500	500	6	12	3000	3500	3000	3500
	2W400	4000	2550	4705	5105	120	120	500	500	6	12	2850	3250	3000	3500
	2W430	4300	2700	5005	5405	120	120	500	500	6	6	2700	3000	2900	3400
	2W450	4500	2800	5205	5605	120	120	500	500	6	6	2550	2850	2850	3350
Duplex ZZ	2F250	2500	1785	3215	3605	1070	680	500	500	6	12	3000	3500	3000	3500
	2F270	2700	1885	3415	3805	1170	780	500	500	6	12	3000	3500	3000	3500
	2F300	3000	2035	3715	4105	1320	930	500	500	6	12	3000	3500	3000	3500
	2F330	3300	2185	4015	4405	1470	1080	500	500	6	12	3000	3500	3000	3500
	2F360	3600	2335	4315	4705	1620	1230	500	500	6	12	3000	3500	3000	3000
	2F400	4000	2435	4715	5105	1720	1330	500	500	6	12	3000	3000	3000	3000
	3F430	4300	2035	5005	5405	1330	930	515	515	6	6	2550	3250	2850	3400
	3F450	4500	2115	5205	5605	1410	1010	515	515	6	6	2400	2850	2700	3300
	3F480	4800	2220	5505	5905	1515	1115	515	515	6	6	2250	2500	2550	3100
	3F500	5000	2305	5705	6105	1600	1200	515	515	6	6	2100	2300	2400	2950
Triplex DZ	3F550	5500	2555	6205	6605	1850	1450	515	515	3	6	1650	1750	2250	2650
	3F600	6000	2805	6705	7105	2100	1700	515	515	3	6	1200	1250	2000	2150

Note: With sideshifter minus 200Kg, with integral sideshifter minus 100Kg.

1. The parameters in the table are of the standard model. For more information, please contact us.
2. The parameters are subject to change without notice.

CPD30FT8 (+H)  
RATED CAPACITIES GRAPH

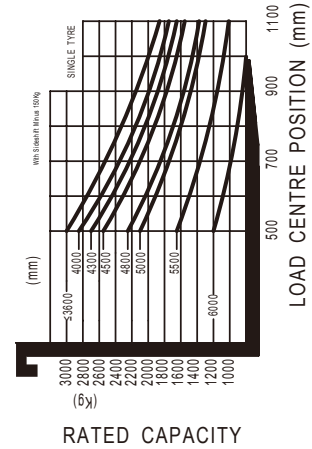

CPD315FT8 (+H)  
RATED CAPACITIES GRAPH

